

Mains fed Water coolers



3M Water Filtration



3M™ AP2-G Range

Specifically designed for mains fed water coolers and drinking water systems.

The Challenge

To provide the best possible quality water to enhance your brand, protect your machine, provide great tasting water and increase your profits.

The Solution

3M's water filter systems provide ease of use and market leading protection for both your product and your machine.

3M™ AP2-G range's unique miniaturisation carbon block technology has half the volume of the existing AP2 range while matching flow capacity and filter efficiency for chlorine and sediment. The new range has been designed to provide the best quality water at the lowest cost to your business and to the environment.

Features	Benefits
53% less plastic than original AP2 range	Reduced disposal costs and lower volume of waste
Sanitary Quick Change Cartridge	For clean and easy change-out
Compact space saving design	For internal and external fitting
Smaller proprietary graded carbon block	No activation or extended flush required, for ease of installation and also reduces the height and diameter of plastic housing
A choice of different media	Reduce chlorine taste and odour Reduce sediment down to 1.0 or 0.5 micron Inhibit scale formation in hot water applications Reduce 99.95% of Protozoan cysts – Cryptosporidium and Giardia Reduce lead and some volatile organic compounds
FDA compliant materials	Can be used in food and beverage applications
Integral mounting bracket on head	For easy installation
Empty cartridge available	Enables simple sanitisation procedure
Built in bypass in head	No water shut-off required
Reduced packaging	Less recycling of packaging required



AP2-401G/401SG/405G/405SG

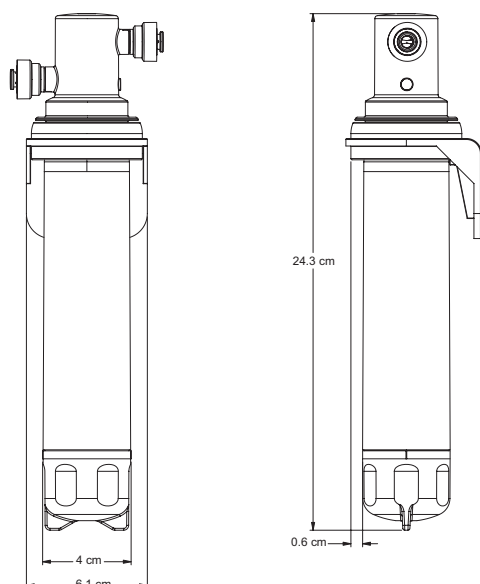

3M™ AP2-G Model Range & Technical Specification

Model*	Part No.	Head	Part No.	Reduction Claims					Capacity (litres)	Flow Rate (lpm)	Temp (°c)	Micron Rating	Case Qty
				Chlorine Taste and Odour	Sediment Reduction	Cyst & Lead Reduction	Scale Inhibition	B, T & D**					
AP2-C401SG	70020252188	AP2 Head	70020042902	x	x		x	x	4,000	2	4.4 - 38	1	25
AP2-C401G	70020252196	AP2 Head	70020042902	x	x			x	4,000	2	4.4 - 38	1	25
AP2-C405SG	70020252162	AP2 Head	70020042902	x	x	x	x	x	4,000	2	4.4 - 38	0.5	25
AP2-C405G	70020252170	AP2 Head	70020042902	x	x	x		x	4,000	2	4.4 - 38	0.5	25
AP2-E	70020025469			Empty cartridge for sanitisation									

*Note that product only comes as replacement cartridge, not as a system
 ** Benzene, Toxaphene & Dichlorobenzene

For the filtration of cold water only. This product is for commercial use only. All materials are FDA compliant with CFR title 21. This is a mechanical, chemical filter. Do not use with water that is microbiologically unsafe or of unknown quality without adequate disinfection before or after the system. Systems certified for cyst reduction may be used on disinfected water that may contain filterable cysts. EPA Establishment No. 070595-MX-001. In line with current good practice and EPDWA guidelines, filter cartridges should be changed every 6 months.

The 3M AP2-G range of products are tested in accordance with NSF/ANSI standard 42 for Chlorine Taste and Odour and, where stated, NSF/ANSI Standard 53 for cyst.

Maximum Operating Temperature is: 38°C
 Maximum Operating Pressure is: 125 psi



Purification
3M United Kingdom plc
 3M Centre,
 Cain Road, Bracknell
 Berkshire RG12 8HT
 Tel: 0845 602 5237
 Fax: +44 (0) 1344 858559
 www.3M.co.uk/waterfiltration

3M Ireland
 The Iveagh Building,
 The Park,
 Carrickmines,
 Dublin 18
 Tel: 1800 320 500